



USER MANUAL

Version 1.0 | 10/08/2024
81350V-240-MAN-EN

HOBBY 350G REVERSE OSMOSIS CONCENTRATOR

The Hobby logo consists of the word 'Hobby' in a bold, black, sans-serif font with a white outline. A stylized water drop icon, colored blue and yellow, is positioned above the letter 'o'.



FIND THE INFORMATION

Record these details for future reference

Date of purchase and invoice number: _____

Serial Number: _____

Representative: _____

Representative's contact details: _____

Table of Contents

FIND THE INFORMATION	2
INTRODUCTION.....	4
NOTES AND INSTRUCTIONS	4
SAFETY INSTRUCTIONS	5
PRODUCT OVERVIEW & TECHNICAL DATA	6
MAIN PRODUCT COMPONENTS	7
LOCATION AND IDENTIFICATION OF PRODUCT COMPONENTS	8
PLUMBING	11
PRODUCT RECEPTION AND INSTALLATION	13
HOW TO REPLACE THE 5 MICRONS PREFILTERING CARTRIDGE.....	14
INSTALLATION OF THE MEMBRANE	15
MEMBRANE DIRECTION (reminder)	18
PROCESS FLOW DIAGRAMOPERATION STEPS	19
DEFROSTING	21
GENERAL STEPS FOR CONCENTRATION.....	22
SINGLE PASS CONCENTRATION	23
DESUGARING	25
RINSE.....	26
SOAP WASH (without wash tank option)	27
SHUTDOWN (DRAINAGE).....	28
PROCEDURE AFTER A POWER FAILURE	29
OPERATING TIPS	29
RECOMMENDATION ON WATER QUALITY	30
CARE AND MAINTENANCE	30
STORAGE.....	31
RESTARTING AFTER STORAGE	33
TROUBLESHOOTING	34
ANNEX.....	35
WARRANTY	38
NOTES	39

INTRODUCTION

Thank you for choosing the Hobby 350G CDL concentrator. We are proud to offer you high quality products designed to meet the demanding needs of the maple sugaring industry. This User's Manual has been designed to help you get the most out of your equipment, by providing clear and detailed instructions for installation, operation, maintenance and troubleshooting.

At CDL, we are committed to constantly innovating and improving our products by offering you the most efficient and reliable solutions. Please read this manual carefully and keep it for future reference. You can also find the manual on our website. If you have any questions or concerns, please do not hesitate to contact our technical support team, who will be happy to assist you.

Thank you for trusting CDL with your maple sugaring equipment needs.

NOTES AND INSTRUCTIONS

1. Read the instructions before installing and using this reverse osmosis system.
2. To avoid damage to the unit, do not disassemble it unnecessarily. Disassembly or reassembly of components may cause breakage and leakage of liquid.
3. To ensure normal system operation, please use cleaning chemicals and filters sold by CDL.
4. When handling, installing or moving equipment, please handle with care to avoid damage to more fragile parts.
5. Before commissioning, install the membrane and 5-micron pre-filter in their respective housings.
6. Rinse and wash the unit thoroughly before concentrating the sap (see membrane rinsing and washing procedure on page 26 & 27).
7. During concentration, do not exceed the recommended pressure of 250 psi. Following this procedure will help reduce yield loss due to membrane clogging.
8. This equipment is not designed for batch concentration above 8 Brix. Concentration capacity varies according to the condition of the membranes, the temperature and quality of the sap, its rate of concentration, as well as the tangential circulation and operating pressure.
9. The membrane must be cleaned daily.
10. If the unit is not to be used for a few days, make sure the membrane is properly washed with soap. After washing and rinsing, circulate a citric acid solution at pH 3 through the membrane to prevent bacterial growth. To do this, add ½ cup of citric acid to 10 gallons of water to obtain a pH of 3. Then stop the unit in the mixture.
11. Rinse equipment before resuming concentration.

SAFETY INSTRUCTIONS

Safety is a top priority when installing and using your equipment. This section provides essential information to ensure safe operation.

Please read all safety instructions carefully before starting any operation. The following pictograms are used in this manual to draw your attention to specific hazards and precautions. Understanding and following these instructions will help you prevent accidents and ensure a safe working environment.

General hazard



This symbol indicates a risk of serious injury or property damage. Please take all necessary precautions to avoid accidents.

Electrical Danger



This symbol indicates a risk of electric shock which may result in serious injury or death. Be sure to disconnect the power supply before attempting any work, and follow the electrical safety instructions.

PRODUCT OVERVIEW & TECHNICAL DATA

The Hobby 350G Concentrator is perfect for maple groves with up to 3,000 taps. It processes up to 350 gallons per hour (GPH) of maple water and is made of durable stainless steel. It is mounted on wheels for easy mobility and features a convenient drainage system. The 1.5 hp pressure pump and recirculation pump, both in stainless steel, ensure optimum performance. Equipped with an 8" 8040 membrane, low-pressure and high-temperature protection, it operates on a 240-volt (20 A) power supply.

Model number :	81350V-240
Recommended number of taps :	≤ 3000
Membranes	1 membrane 8" x 20" equipped with a 240 V - 3,5 A recirculation pump
Water Disposal	350 GPH to 250 psi @ 5-6 concentrated Brix
Maximum pressure pump flow :	350 GPH
Maximum operating pressure	300 psi
Maximum concentration	8 Brix
Power consumption at 250 psi :	≤ 15 A
Empty weight :	122 kg (270 lbs)
Empty weight with membrane :	135 kg (298 lbs)
Shipping dimensions :	27,25 in x 69,125 in x 26,75 in
Included :	<ul style="list-style-type: none"> • 1 membrane 8" x 40" • 1 prefiltered cartridge 2" x 10" • Tool for prefiltered box
Testing conditions :	Sap temperature 13 °C, 2 Brix at input, 6 Brix at output, 250 psi operating pressure.

Note: Concentration capacity and volume of water treated per minute may vary according to the type of membrane used.

MAIN PRODUCT COMPONENTS

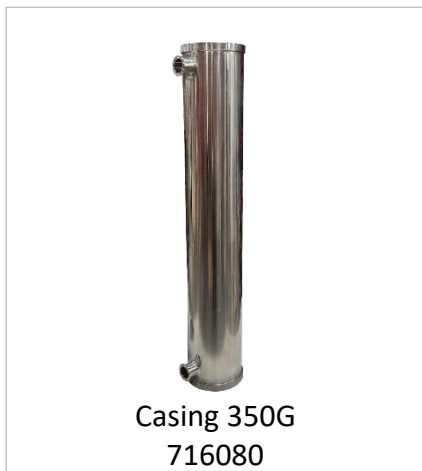

Casing 350G
716080



Prefiltered 5 microns cartridge
6682101



CDL 8'' Membrane
66016980



1.5hp Motor
668018



Recirculation 1 hp pump
assembly



10'' cartridge housing
665010



Citric acid 1kg (powder)
66994

BIO Membrane soap
"Superflow green" 1 kg
(powder) 662403



Stainless steel pressure pump
71706

LOCATION AND IDENTIFICATION OF PRODUCT COMPONENTS

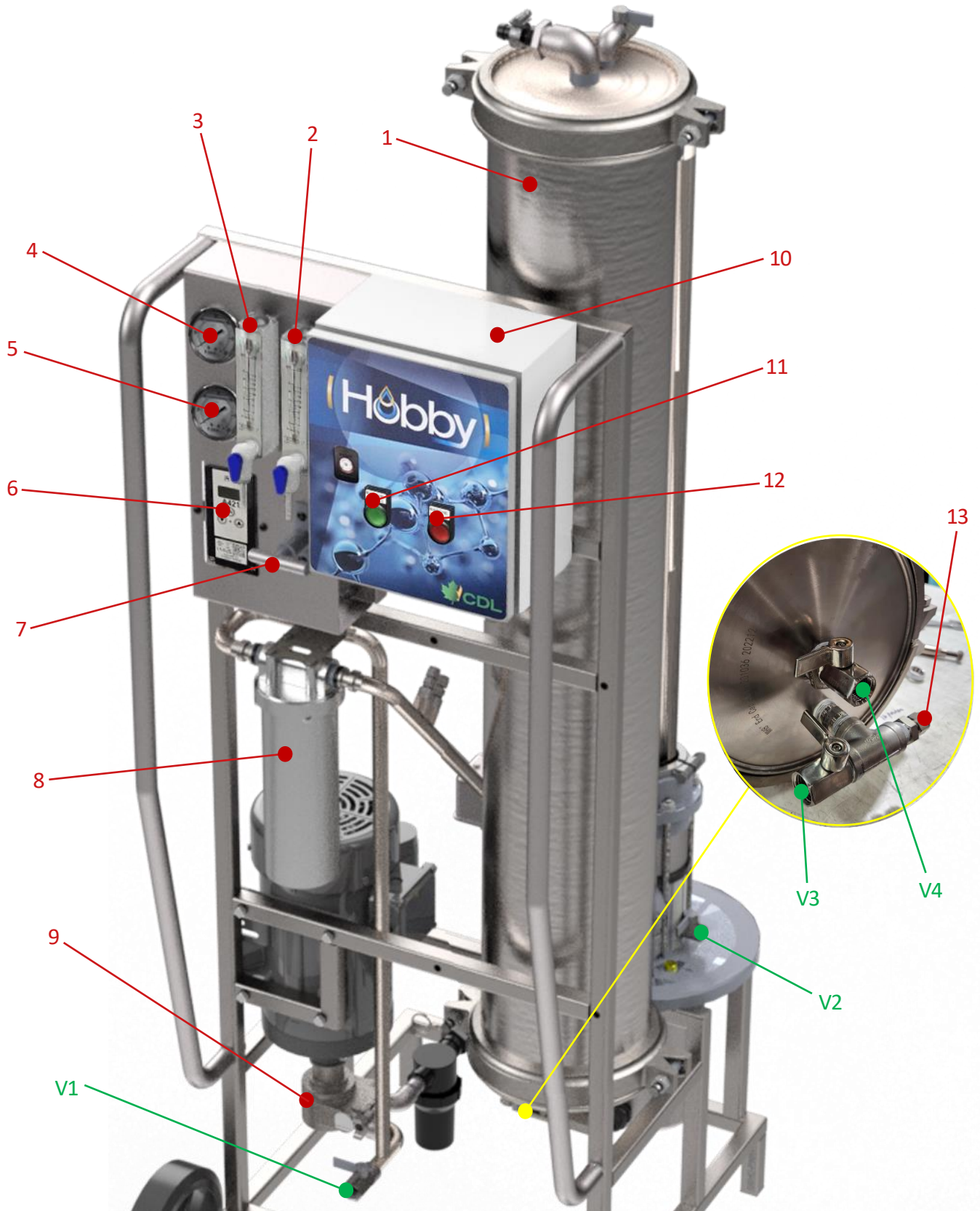

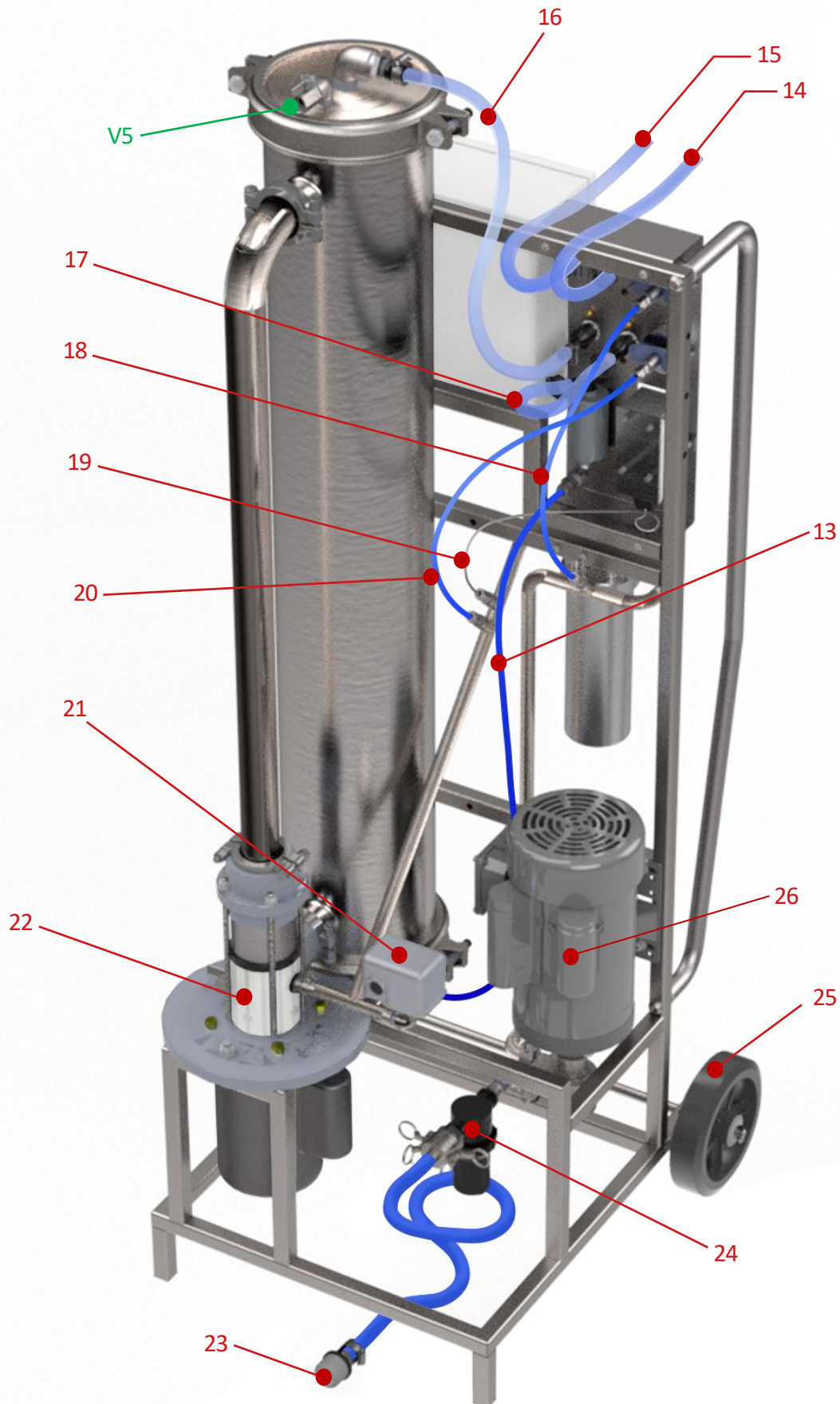

#	DESCRIPTION	#	DESCRIPTION
1	8" MEMBRANE CASING	14	CONCENTRATE OUTPUT TO CONCENTRATE TANK
2	FILTRAT FLOWMETER	15	FILTRAT OUTPUT TO FILTRAT TANK
3	CONCENTRATE FLOWMETER	16	FILTRAT OUTPUT to FILTRAT FLOWMETER
4	PRESSURE GAUGE BEFORE FILTER	17	CONCENTRATE VALVE OUTPUT TO CONCENTRATE FLOWMETER
5	PRESSURE GAUGE AFTER FILTER	18	PRESSURE LINE BEFORE FILTER
6	TEMPERATURE CONTROL	19	TEMPERATURE SENSOR WIRE TO TEMPERATURE CONTROLLER
7	CONCENTRATE VALVE	20	PRESSURE LINE AFTER FILTER
8	FILTERING 10" CARTRIDGE HOUSING	21	PRESSURE CONTROLLER
9	FEEDING PUMP 325GPM	22	1 HP RECIRCULATION PUMP ASSEMBLY
10	ELECTRICAL PANNEL	23	1/2" STRAINER
11	STARTING SWITCH (ON)	24	1/2" LINE FILTER
12	STOPPING SWITCH (OFF)	25	8" X 5/8" RUBBER RING
13	CONCENTRATE OUTPUT TO CONCENTRATE VALVE	26	1.5HP ELECTRICAL MOTOR

#	VALVE IDENTIFICATION
V1	FEED PUMP OUTLET MANIFOLD DRAIN VALVE
V2	RECIRCULATION PUMP DRAIN VALVE
V3	DRAIN VALVE FOR CONCENTRATE SECTION OF MEMBRANE
V4	DRAIN VALVE FOR FILTRAT SECTION OF MEMBRANE
V5	AIR BLEED VALVE FOR THE MEMBRANE CASING

PLUMBING

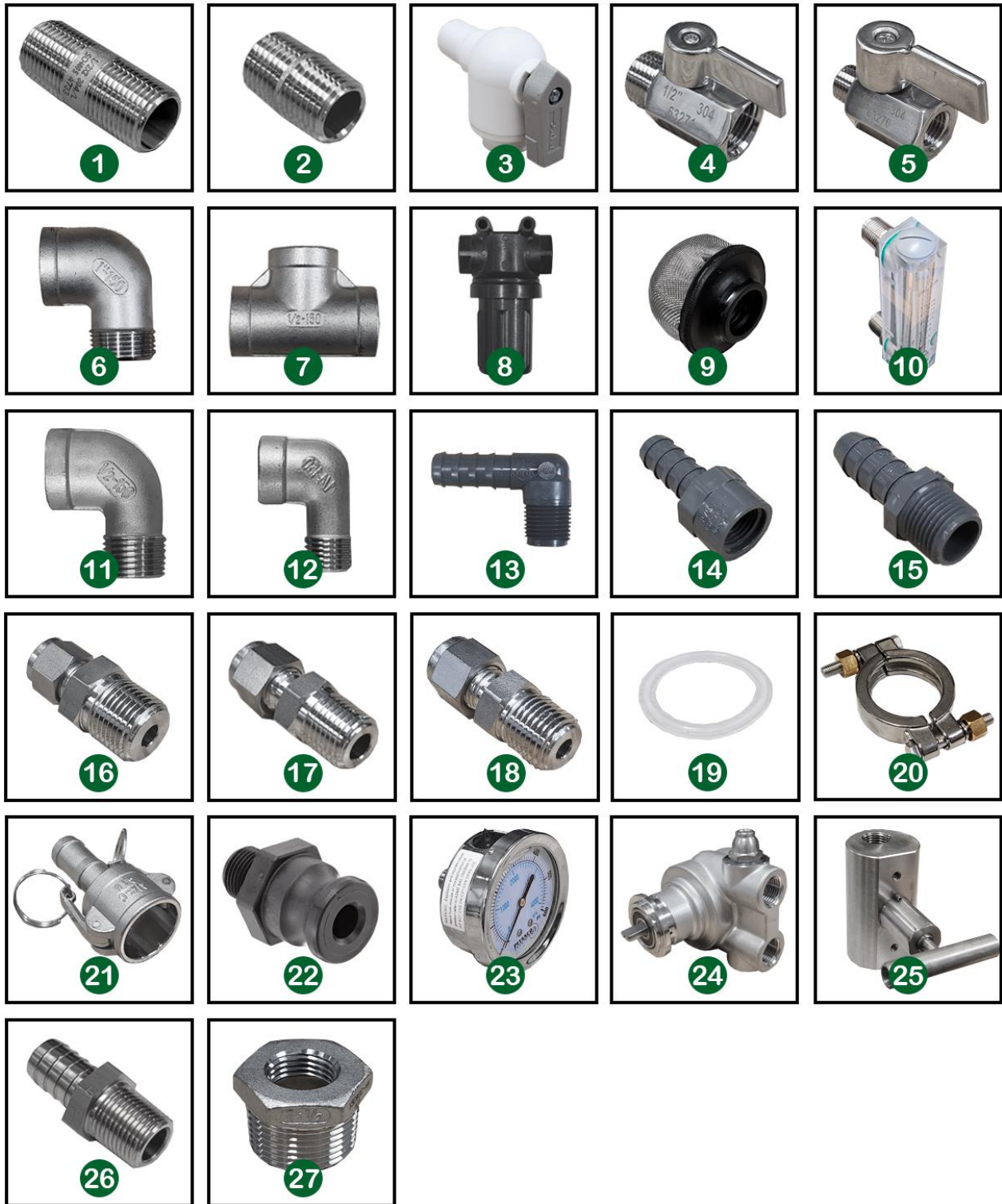

#	DESCRIPTION	PRODUCT NUMBER	#	DESCRIPTION	PRODUCT NUMBER
1	1/2" X 2" STAINLESS STEEL NIPPLE	601105002	15	PVC ADAPTOR 1/2" INS-MIPT	66195
2	1/4" CLOSE STAINLESS STEEL NIPPLE	610151	16	1/2" MIPT X 3/8" SLEEVE STAINLESS STEEL ADAPTOR	712038
3	90° 1/4" VALVE NPT X 1/4" TUBE	6622312	17	1/4" MIPT X SENSOR STAINLESS STEEL ADAPTOR	664544P
4	1/2" STAINLESS STEEL BALL VALVE MIPT X FIPT	63271	18	1/4" MIPT X SLEEVE STAINLESS STEEL ADAPTOR	664544S
5	1/4" STAINLESS STEEL BALL VALVE MIPT X FIPT	63270	19	2" SILICONE O-RING FERRULE	60GASKET2SILI
6	1" STAINLESS STEEL ELBOW MIPT-FIPT	601090	20	2" STAINLESS STEEL HIGH PRESSURE CLIPS	6013MHP200
7	1/2" STAINLESS STEEL T FIPT	711212	21	3/4" (C) QUICK STAINLESS STEEL ADAPTOR	662090075
8	1/2" LINE FILTER	66206042	22	1/2" (F) BANJO POLYPRO QUICK STAINLESS STEEL ADAPTOR	6620105
9	STRAINER 1/2" 40 MESH	663357	23	GLYCOL MANOMETER 600PSI STAINLESS STEEL OUTPUT	663337SS
10	0-5 GPM FLOWMETER 1/2" MIPT STAINLESS STEEL	661033	24	STAINLESS STEEL HOBBY 325 GPM FEED PUMP	71706
11	1/2" MIPT_FIPT STAINLESS STEEL ELBOW	60109S05	25	CDL 1/2" STAINLESS STEEL CONTROL VALVE	71090
12	1/4" MIPT-FIPT STAINLESS STEEL ELBOW	6010913	26	1/2" X 5/8" MIPT-INS STAINLESS STEEL VALVE	710563
13	PVC ELBOW 1/2" INS-MIPT	66280	27	1" X 1/2" MIPT-FIPT STAINLESS STEEL REDUCER	711012
14	PVC ADAPTOR 1/2" INS-FIPT	64091			

PRODUCT RECEPTION AND INSTALLATION

A quick visual check should be carried out on the machine on receipt of the concentrator to identify any breakages or faults in the system. This verification should also be carried out before use.

Ensure that the separator is installed in accordance with the requirements below. Failure to comply with CDL's recommendations may affect the product's longevity.

Site preparation (Prerequisites)

Electricity

The machine must be connected to a single-phase 220 V electrical outlet. It is important to use a 20 AMP circuit breaker and to check that the wire gauge is adequate. Use a type L6-20R female plug to connect the machine. If an extension cord is to be used, it is important to have a minimum wire size of 12 AWG. Using an extension cord that is too long or too small will overload the motor. This overload can cause the product to overheat and break down.

Plumbing

The concentrator has an 8-foot suction line. It is important not to extend this tube, as the pump may run dry for too long during priming, damaging internal parts. To avoid cavitation of the feed pump, it is important not to place the pump higher than 2 meters from the bottom of the pond.

HOW TO REPLACE THE 5 MICRONS PREFILTERING CARTRIDGE

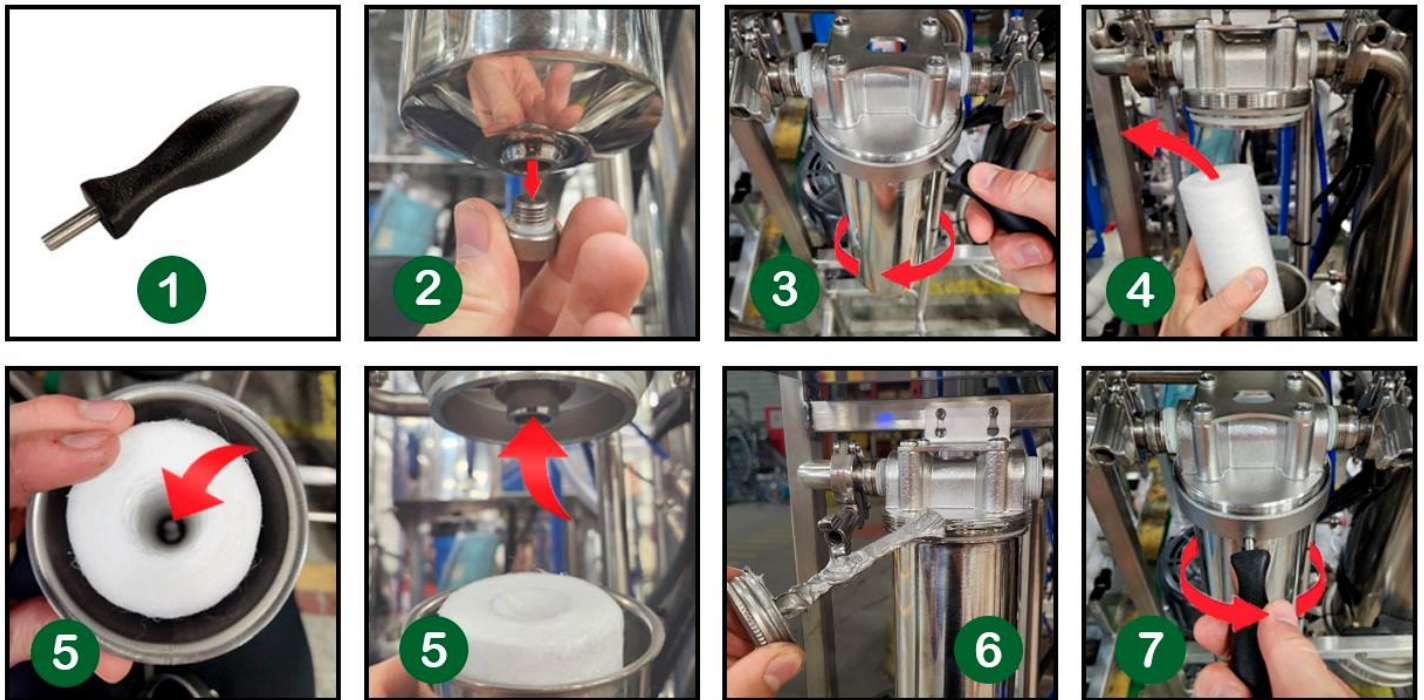

1. Make sure you have the cartridge casing tightening tool (normally located in the osmosis electrical panel).
2. Make sure to empty the cartridge casing of all liquids by removing the drain plug located under the case.
3. Using the tool, unscrew the tightening ring from the casing.
4. Remove the filter housing and remove the old cartridge from its location.
5. Take a new 5-micron cartridge (6682101), install it in the housing, then ensure that the 2 ends of the cartridge fit in the appropriate places (see arrow) before fitting the casing on the filter head.
6. To prevent the threads of the casing from seizing, apply anti-seize to the male threads on the cartridge housing.
7. Install the housing on the head, and using the tool, retighten the housing tightening ring.

*** To install a cartridge in a previously empty cartridge case, follow the same steps, skipping the fourth where the old cartridge is required to be removed. ***

INSTALLATION OF THE MEMBRANE



- Next, lay the osmosis unit on its front face to facilitate removal of the covers and insertion of the membrane.

3. Have wrenches or other 7/8" tools on hand to unscrew the 2 1/2" bolts from the 2 covers.
4. Remove bottom cover and gasket.

Note: It may be difficult to remove the clamping collars from the cover due to its proximity to the other components. It can therefore be left in place without interfering with any other handling.

5. Once the lid has been removed, simply remove and retain the permeate adapter (1) and membrane spacer (2) before replacing the lid.
6. Remove the top cover, then remove and save the second permeate adapter.
7. Insert the membrane spacer through the top opening and push it to the bottom of the chamber.
8. Take 1 of the 2 permeate adapters and ensure that all its O-rings are lubricated with grease (use MOLYKOTE 111 grease).
9. Insert the permeate adapter in the membrane central tube.

Note 1: It is extremely important to insert the adapter with the longest thin-diameter section into the membrane (see blue box) and the shortest section out.

Note 2: It is extremely important, at this stage, to insert the adapter into the central hole of the membrane, on the side **where there is no gasket** around the membrane (see green box).

10. Insert the membrane into the box through the top opening, putting the end without the gasket first (the one shown in step #9 (green box)).
11. Push the membrane to the bottom of the vessel, ensuring that the gasketed end (yellow box) is towards the top opening.
12. Ensure that the membrane is inserted all the way and that the permeate adapter installed in step #9 is properly inserted in the bottom cover.
13. Measure the distance between the top of the membrane and the edge of the chamber. The distance should be about 4-3/8".
14. Take the remaining adapter and make sure all its O-rings are lubricated with grease (use MOLYKOTE 111 grease).
15. Insert 2nd permeate adapter.

Note 1: It is extremely important to insert the adapter with the longest thin-diameter section into the membrane (see first image of step #15) and the shortest section out (see second image of step #15).

Note 2: It is extremely important, at this stage, to insert the adapter into the central hole of the membrane, on the side **where there is a seal** all around the membrane end cap.

16. Return the osmosis unit to its upright position and replace the lid, gasket and collar.
17. Apply anti-seize to the threads of all 1/2" bolts on the 2 collars before tightening firmly on each side.
18. Finally, when tightening, make sure that the distances between the collars are the same for both pairs of collars (red arrows). Also, check that the top lip of the cover is level with the top of the clamping collar (green arrows).

MEMBRANE DIRECTION (reminder)

When it's time to install or change the concentrator's membrane, it's important to install it the right way, to avoid leaks and to optimize concentrator performance. Each membrane has a brine seal at the end through which the concentrate enters. This must be used as the basis for correct membrane installation.

In the Hobby 350G, the membrane is installed as follows (see drawing below):

- The diaphragm's brine seal must face upwards.



PROCESS FLOW DIAGRAM

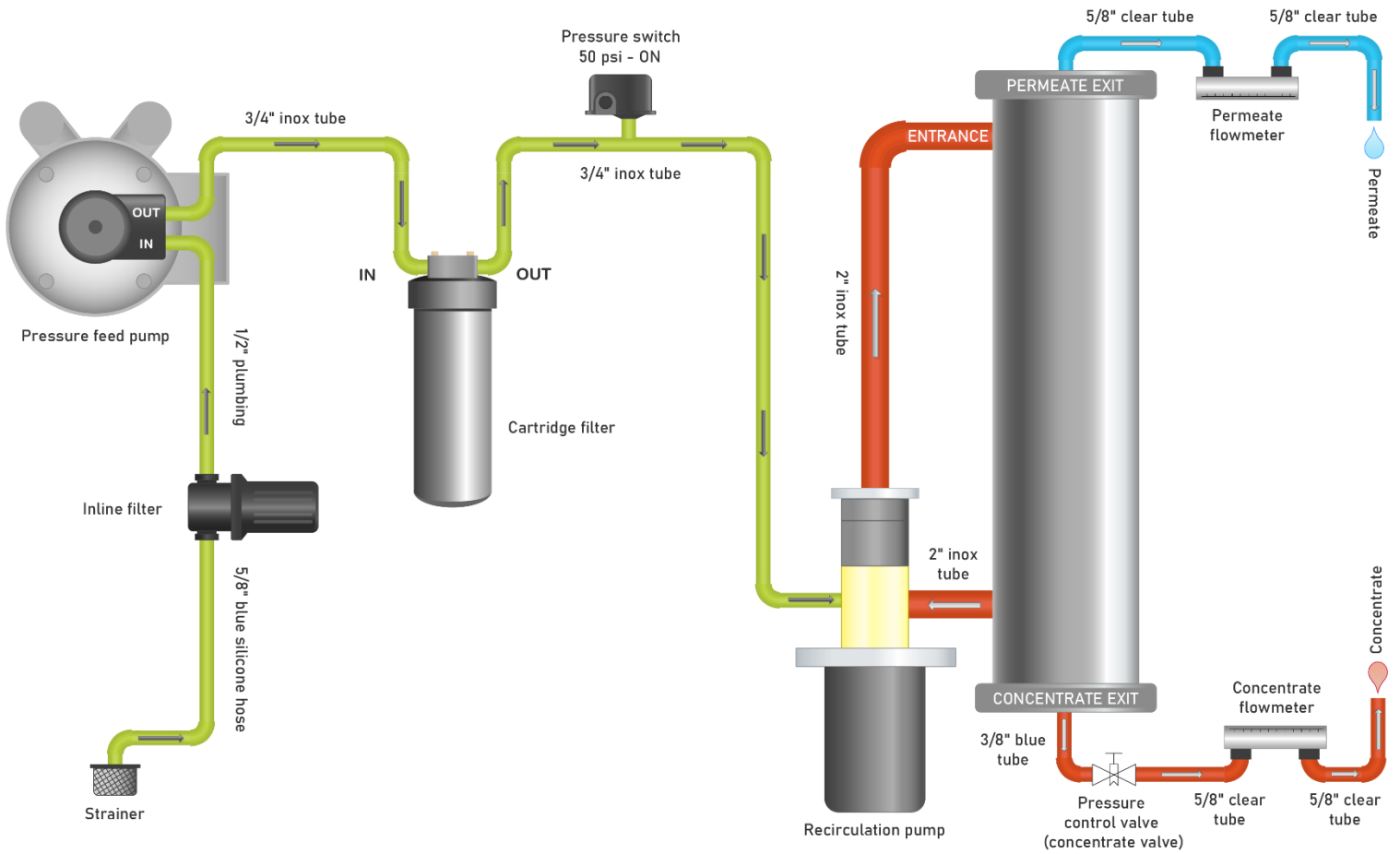

OPERATION STEPS

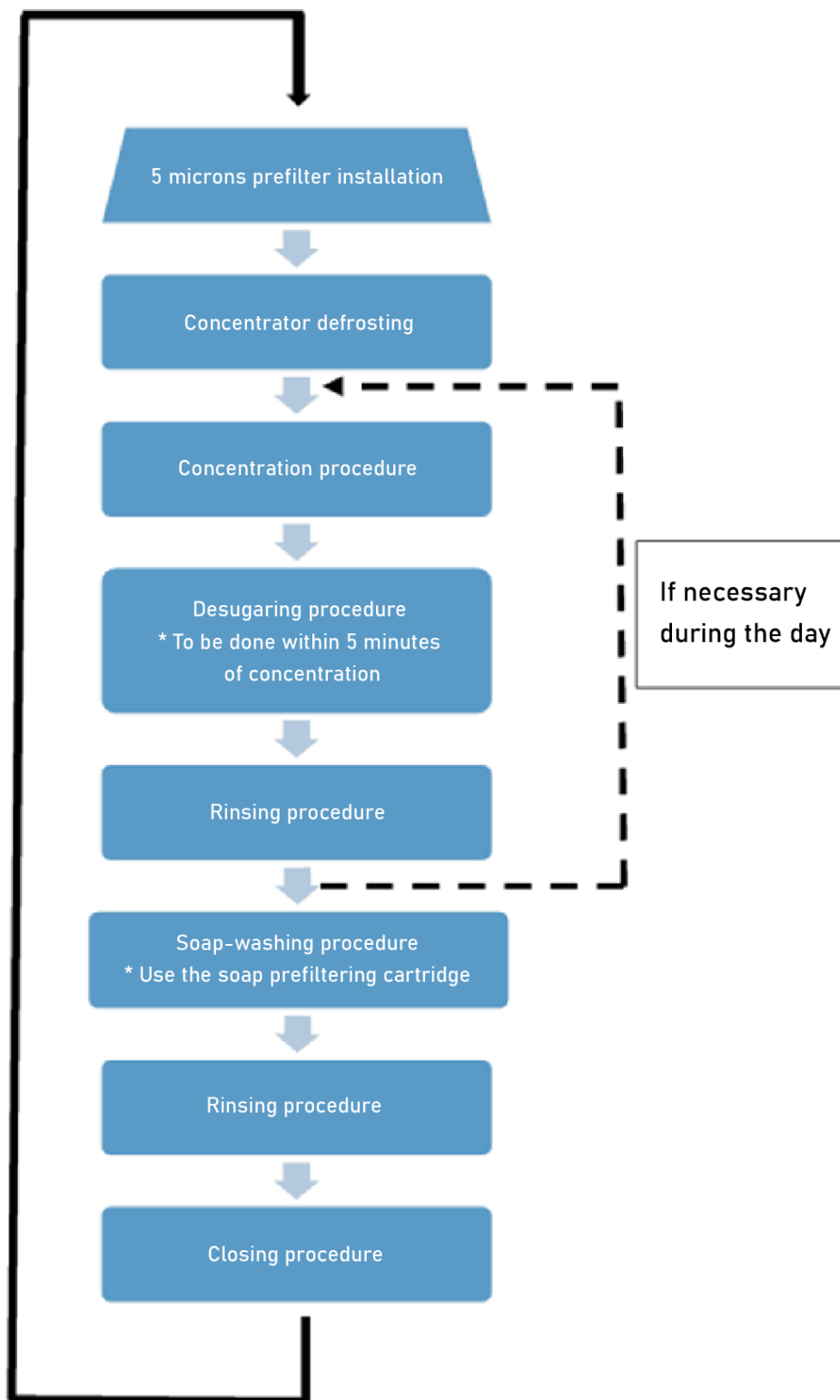

DEFROSTING

If the concentrator is to be used after being exposed to freezing temperatures, it must be defrosted before use. To do this, use a hot-air gun to heat the stainless-steel outer surface of the feed pump. A towel soaked in hot water can also be used. In this case, wrap the towels around the stainless-steel parts of the pumps and leave to warm up for several minutes to ensure that no ice remains inside the pump. If necessary, add new hot water to the towels.

IMPORTANT



Do not overheat the recirculation pump, it will damage seals. Also, do not use a propane torch, as the higher heat could melt the pump seals.



If the concentrator is left at below freezing temperature, it must be rapidly drained to avoid freezing.



GENERAL STEPS FOR CONCENTRATION

1. Close the 4 drain valves, the purge valve and the two sampling valves.
2. Screw on the line filter container at the feed pump inlet.
3. Install the pre-filter. *Ideally, use a cartridge other than the wash cartridge. Make sure you have screwed on the plug below the prefilter (drain plug).
4. Ensure that the blue supply hose is connected to the pump.
5. Open concentration valve to maximum.
6. Connect the concentrator to a 220 V outlet.
7. Insert blue suction hose into sap tank.
8. Place filtrate and concentrate hoses in appropriate tank(s) according to concentration method (1-pass or batch).
9.  *****IMPORTANT***** If the unit has been exposed to frost, defrost the concentrator before operating the pump (see page 21).
10. Hold down the green start button and gradually close the concentrate valve handle until the pressure switch engages. The recirculation pump will then start up. Run at low pressure until there is no more air in the flowmeters.
11. Gradually adjust the concentrate valve so that the concentrate and filtrate have the same flow rate.
12. Periodically monitor operating parameters.
13. When concentrating is complete, gradually lower the pressure using the concentrate valve until the concentrator stops automatically.

*Caution: do not wait until the concentrator runs out of sap, as the pumps may run dry for too long before stopping.

*Do not concentrate higher than 8 brix.

SINGLE PASS CONCENTRATION

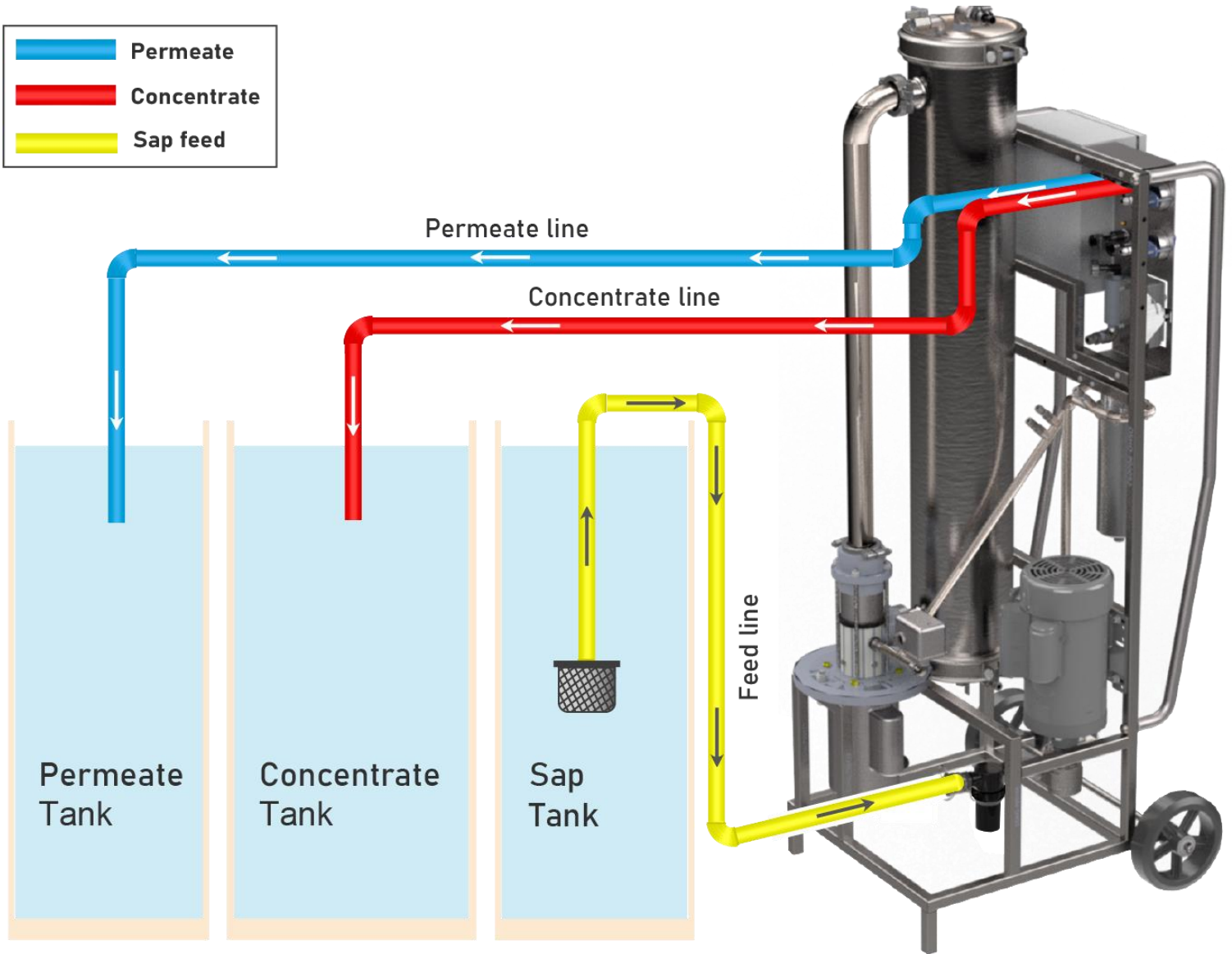

BATCH CONCENTRATION

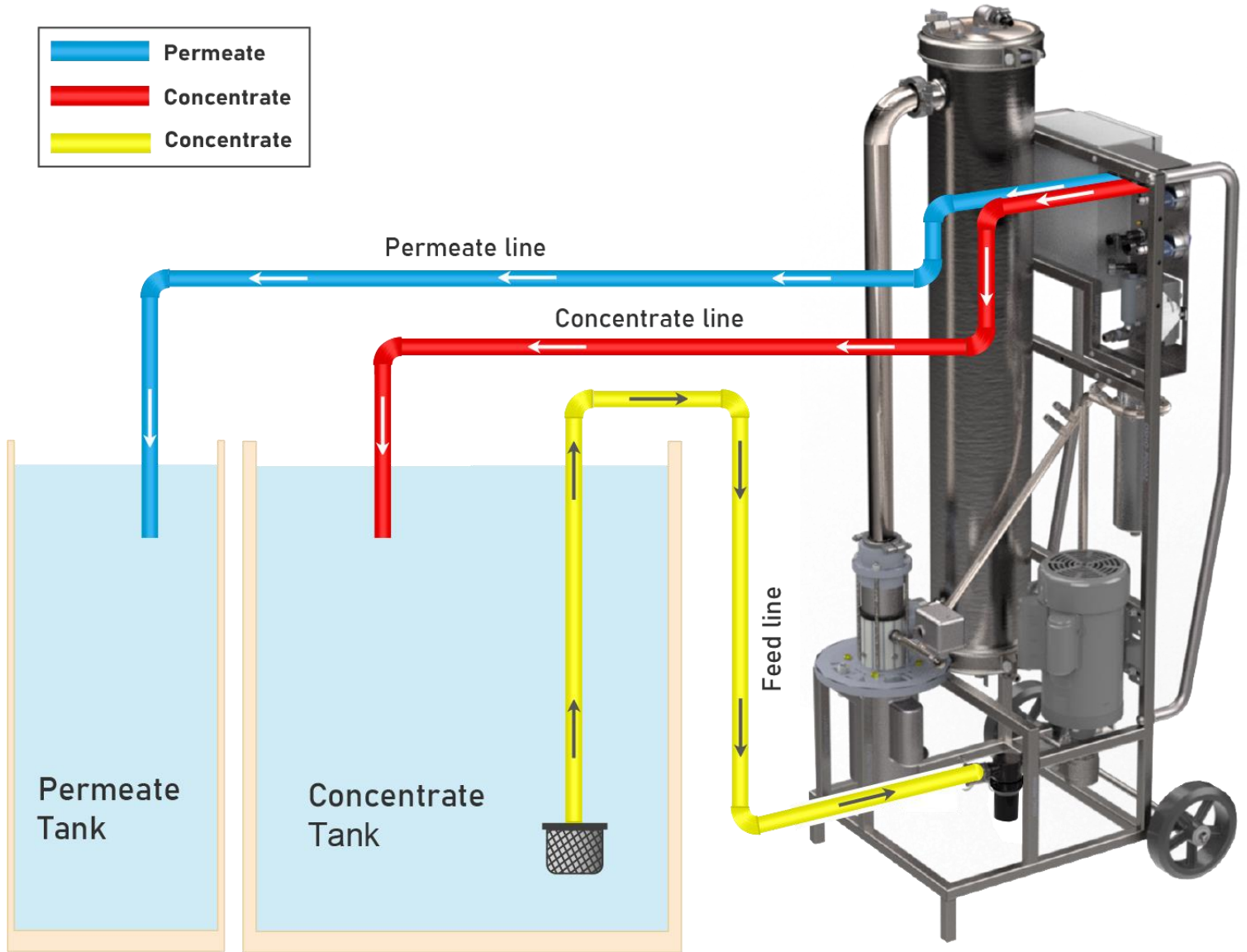

DESUGARING

- Execute the operations shown in the diagram below.
- Start the concentrator to begin the desugaring cycle (step 9 of the concentration cycle).
- Take a sample of concentrate at regular intervals until the concentration is 0.5 Brix.
- Stop the concentrator.

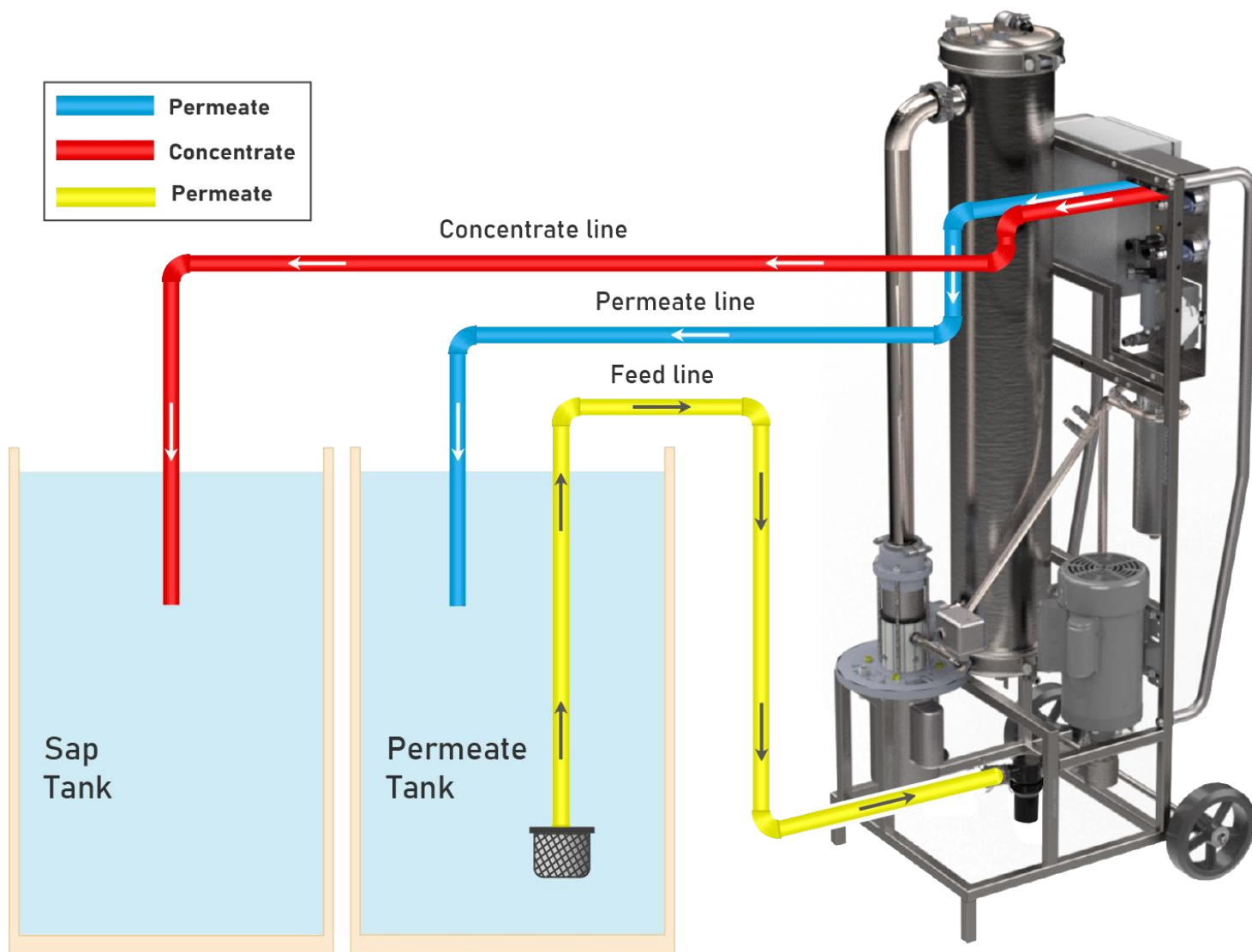

RINSE

- Execute the operations as shown in the diagram below.
- Start the concentrator and adjust the pressure to 60 psi. A minimum of 250 gallons of filtrate must flow through the membrane.
- Stop the concentrator when the recommended amount of water has been reached.

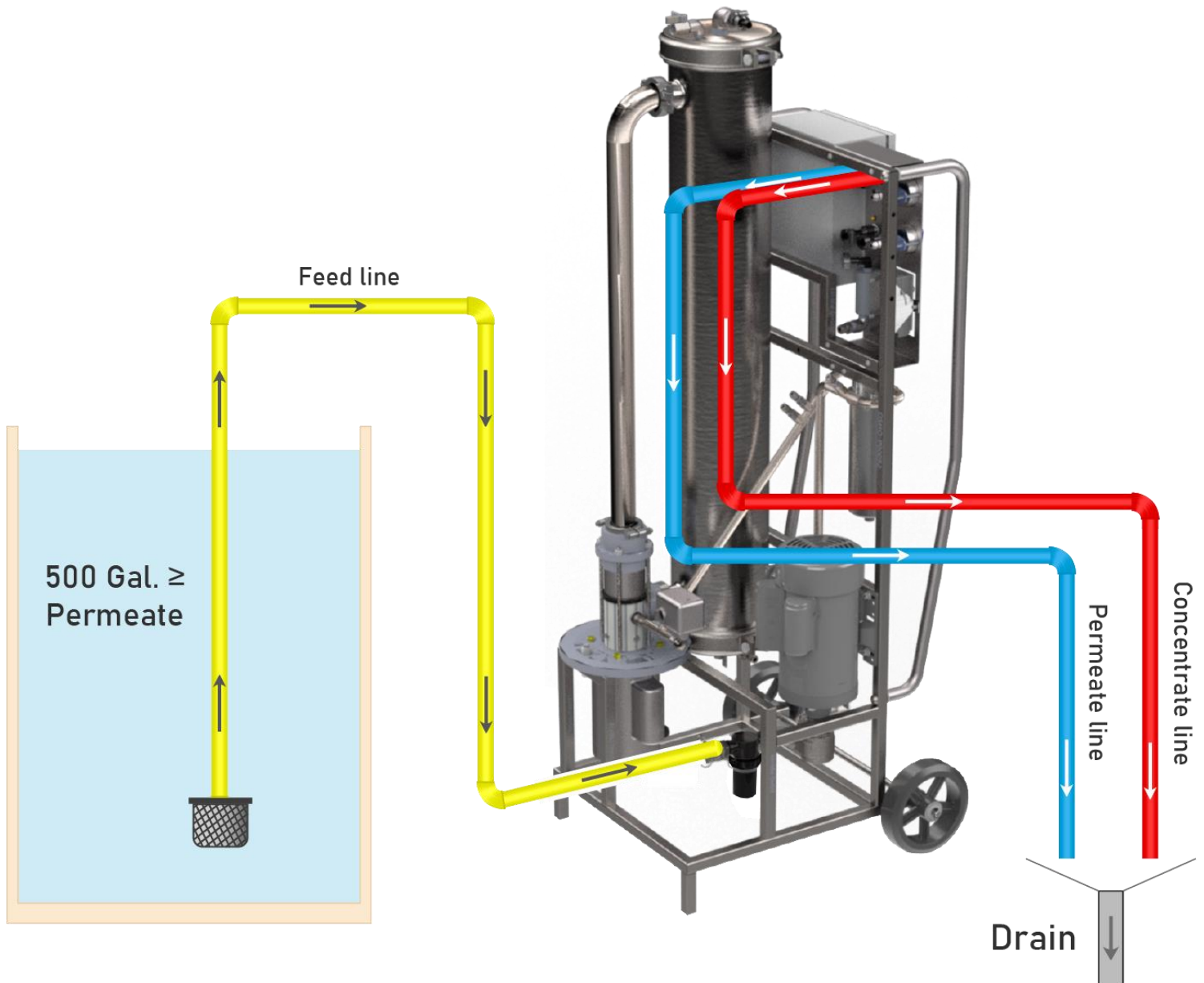

SOAP WASH (without wash tank option)

- In the pre-filter casing, replace the existing 5-micron cartridge with a dedicated soap wash cartridge.
- Follow the instructions in the diagram below.
- Adjust pressure to 60 psi and wash in a loop until the concentrator stops. The wash cycle will end at a temperature of 43°C/109.4°F. Perform final rinse with all remaining filtrate.
- After washing, be sure to drain any wash solution remaining in the concentrator (see page 28).
- After draining, it is recommended to rinse the concentrator with a quantity of permeate representing 30 to 40 times the dead volume of liquid contained in the unit. This represents a minimum of 250 gallons of permeate (see page 26 for rinsing procedure).

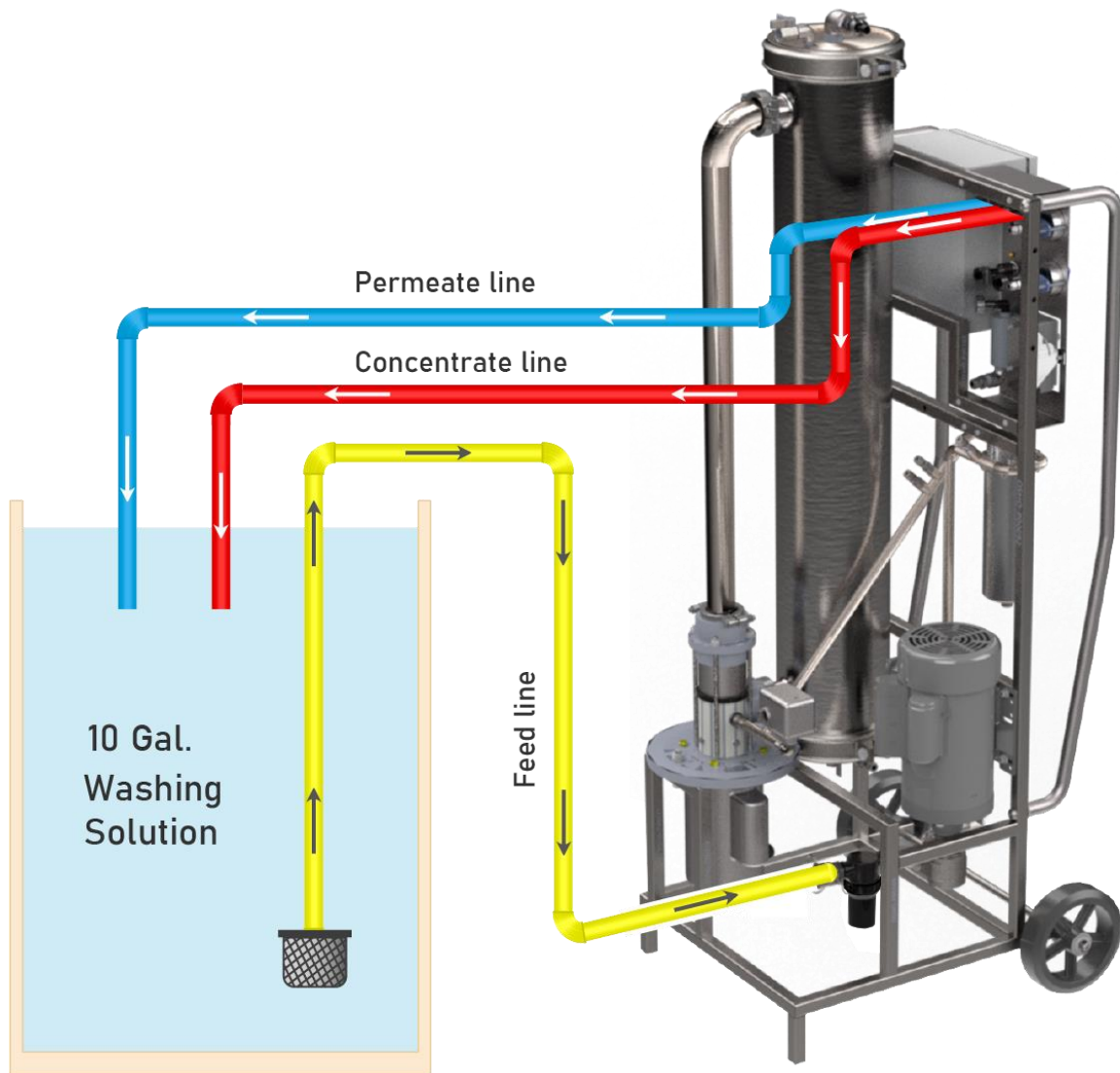

SHUTDOWN (DRAINAGE)

- Open the 4 drain valves, the purge valve and the 2 sampling valves.
- Unscrew the line filter container at the feed pump inlet and the strainer to remove residual water.
- Proceed as shown in the diagram below.
- Hold the green start button for 2 seconds. This will evacuate any water remaining inside the feed pump.
- Repeat the previous step, twice at 10-second intervals.
- Disconnect the concentrator from its power supply.

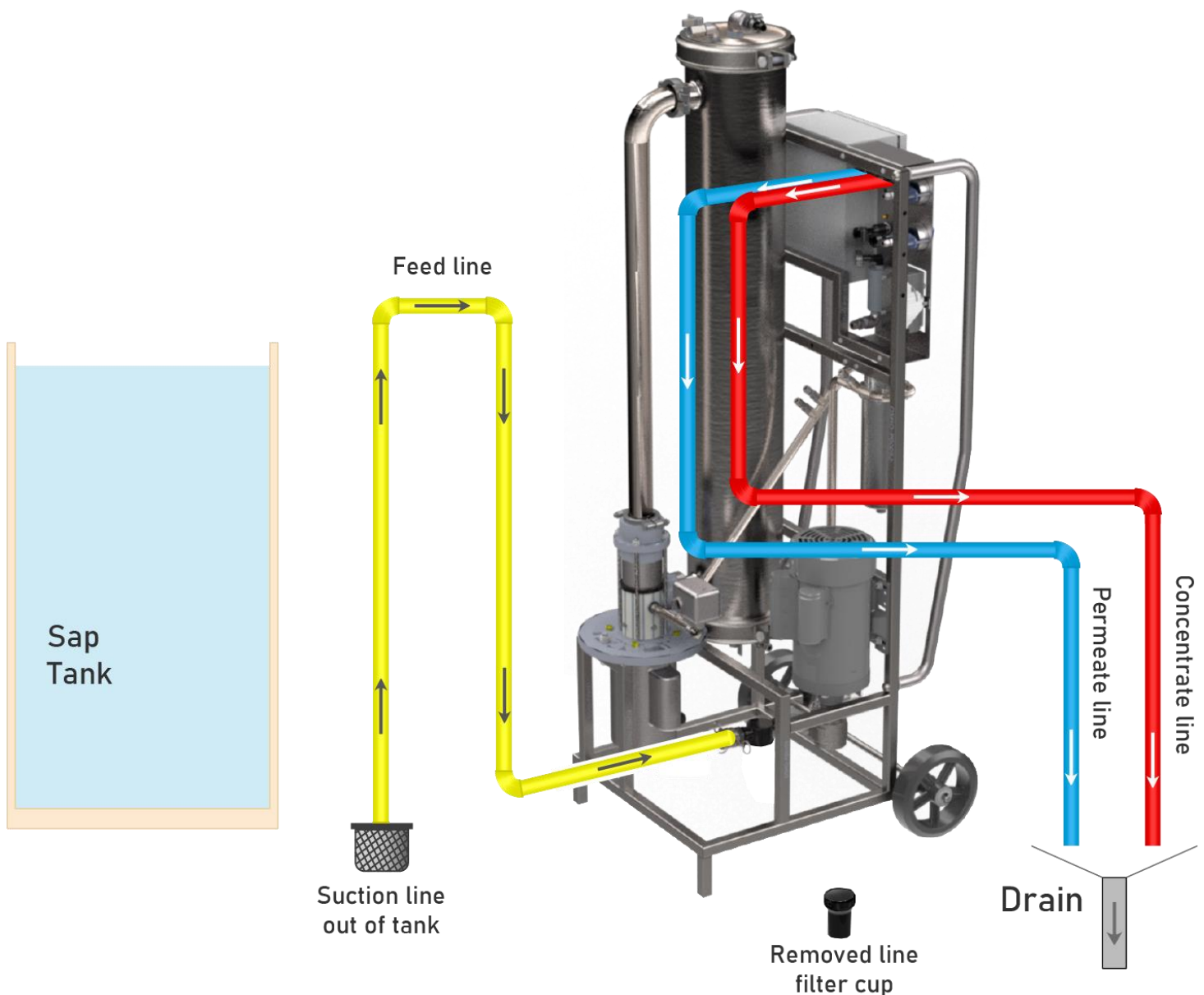

PROCEDURE AFTER A POWER FAILURE

If the concentrator has stopped after a power failure, check that no ice has formed inside the pumps. Then follow the rinsing procedure before resuming concentration.

OPERATING TIPS

For optimum concentrator performance, here are a few tips to follow:

- Follow the rinse and wash cycles after each use.
- During the wash cycle, reach the stop temperature of 43°C/109.4°F. Washing is more effective at this temperature than when cold.
- Use a different pre-filter cartridge when washing and concentrating.
*****IMPORTANT***** Do not leave membranes in maple water for more than 5 minutes without operation. Bacteria in the sap will clog the membrane surface.
- If water other than the filtrate is used for rinsing, make sure it does not contain iron or manganese.
- The end-of-season procedure will help extend the useful life of the membranes.

RECOMMENDATION ON WATER QUALITY

The quality of the water used for rinsing and cleaning membranes must be of the highest quality to avoid undesirable deposits on the membrane. In most cases, municipal or artesian well water is not considered to be of “acceptable quality”. Particular attention must be paid to particles with clogging potential, such as iron, manganese, limestone and silicates.

Clean water must always comply with the following specifications:

Clogging particles	Minimum requirements
Iron (Fe)	<0,05 ppm
Manganese (Mn)	<0,02 ppm
Silicate (SiO ₂)	<5ppm
Aluminium (Al)	<0,05 ppm
Hardness	<85 ppm in CaCO ₃
Particles Size	<10 microns
Turbidity	<1 NTU

Important note: When available, reverse osmosis filtrate should always be used for membrane washing, rinsing and storage.

CARE AND MAINTENANCE

Cleaning and replacing filters:

- It is essential to clean the line filter before each use. A clogged filter will create a restriction at the pump inlet, resulting in cavitation. The pump will then suffer premature wear and tear, and its useful life will be impaired.
- The pre-filter cartridge should be replaced by a new one when there is a pressure difference of 20 psi between the two pressure gauges.

STORAGE

Shutdown procedure at the end of the season:

1. Soap wash

Soap wash (662403) must be repeated until the solution in the wash tank remains clear. It is important to perform a short rinse between each wash.

2. Citric acid treatment

Once the soap washes (66994) have been completed and the equipment rinsed, proceed with the citric acid treatment.

- Add 2 cups of granulated citric acid to 10 gallons of hot water at 35°C.
- Circulate for one hour and soak for 12 to 24 hours.
- Recirculate for 10 minutes and drain.
- Rinse with 250 gallons of permeate or quality drinking water.

3. Sanitizing with peracetic cleaner (#62298)

Before storing, it's a good idea to sanitize the membrane and equipment with a solution of quality water and peracetic acid. This step eliminates micro-organism contamination of the membrane.

- Recirculate a solution of 1 oz of peracetic acid per gallon of good quality water contained in the unit and the wash tank.
- Circulate the solution for 30 minutes. Do not exceed 25°C.
- Soak for 12 to 24 hours.
- Drain the unit.
- Rinse with 250 gallons of good quality water.

4. Citric acid storage method (#66994)

- Mix 1 cup of citric acid with 4 liters of food-grade glycol.
- Circulate the solution for 15 minutes to mix well with the water in the unit and the membrane. Leave solution in unit until next season.
- **Important note:** Store the unit in a frost-free place.
- **Important note:** For best results, it is important that the procedure for each step is carried out correctly, to prevent contamination. The water used must be of good quality and potable.



5. Membrane storage

- Once the membrane has been washed, it must be stored in the osmosis unit or in a vessel. If the membrane is stored in a storage vessel or airtight bag, use CDL No. 80000 storage solution. Remove the brine seal (u-cup) and add one tablespoon of solution for a vessel full of filtrate. To do this, lay the separator flat (on its handles) and pull out the membrane. In this way, the liquid remaining in the chamber will not run onto the concentrator motors. If the membrane is stored in the osmosis unit, fill the machine with filtrate and 4 liters of food-grade propylene glycol No. 88020. Leave the membrane in this solution and cap the feed pipes (filtrate and concentrate) tightly. No air should enter the system.
- Never store the membrane in the concentrator with storage solution No. 80000 (sodium metabisulfite), as this will attack the housing covers and seals. The membrane must be protected from freezing.

Important note: During storage, the membrane must always be kept moist.

RESTARTING AFTER STORAGE

Before concentrating the first sap of the year, it is important to take the following steps:

1. Insert a new prefilter cartridge.
2. Install the membrane in the separator. Pay attention to the direction of the brine seal (u-cup).
3. Rinse with drinking water containing no iron or manganese.
4. Wash with soap.
5. Perform a long rinse.

Once these steps have been completed, you can begin the maple sap concentration process.

TROUBLESHOOTING

This troubleshooting section is designed to help you quickly identify and solve any problems you may encounter with your equipment. In the event of persistent difficulties, your sales representative or our customer service team will be happy to offer further assistance.

Problems and solutions:

Problem	Cause	Solution
The system won't start	<ul style="list-style-type: none"> • Power supply is not connected • A fuse may be blown 	<ul style="list-style-type: none"> • Check electrical panel circuit breakers • Check fuse status
Recirculation pump won't start	<ul style="list-style-type: none"> • Pressure on membrane side not high enough • No sap coming to concentrator • Air entering the system • Pressure switch not operating normally 	<ul style="list-style-type: none"> • Gradually turn the concentrate valve during start-up. • Check that the feed hose is not blocked and is positioned below the sap level. • Check condition of feed hose • Check that there is no ice blocking the pressure switch • Turn switch on recirculation pump to "ON"
Filtrate flow tends to decrease	<ul style="list-style-type: none"> • Membrane needs washing • Sap Brix too high • Recirculation pump not working 	<ul style="list-style-type: none"> • Run a wash cycle and repeat as necessary. • Reduce concentration if above 8 Brix. • Stop concentrator if Brix is higher than 8 • Make sure recirculation pump is working properly.
Feed pump makes irregular noise	<ul style="list-style-type: none"> • Line filter clogged, air entering system • Vacuum strainer clogged • No sap coming to pump 	<ul style="list-style-type: none"> • Clean line filter. • Check vacuum strainer for blockage. • Check vacuum hose for blockage. • Check that vacuum hose is properly connected.
Wash cycle does not automatically stop	<ul style="list-style-type: none"> • Temperature is below 43 °C 	<ul style="list-style-type: none"> • Preheat filtrate at 40 °C
No water out of sampling valves	<ul style="list-style-type: none"> • Filtrate and concentrate hoses are too low 	<ul style="list-style-type: none"> • Place the hoses higher than the flowmeters

ANNEX

PEP Test

PEP (Pure Water Permeation) is a measure of membrane performance. By comparing it with the initial PEP, this figure enables us to calculate the membrane's performance losses throughout the season. The initial PEP should be noted after the first 20 hours of use. A correction factor will be used, as the filtrate flow rate varies with temperature. Values will therefore always be recorded as if the temperature were 13°C.

How to calculate:

1. Start the concentrator in rinse mode using filtrate.
2. Adjust the concentration valve to 60 psi on the diaphragm side.
3. When the flowmeters have stabilized and there are no air bubbles, note the filtrate flowmeter value.
4. Record the water temperature.
5. Divide the filtrate value obtained by the temperature correction factor.

Calculation Example

Initial PEP after 20h of use:

$$\frac{1,1 \text{ GPM (filtrate flow)}}{0,790 \text{ (Temperature of } 5^{\circ} \text{ C)}} = 1,392 \text{ GPM}$$

PEP after rinse (PEP during the season):

$$\frac{0,9 \text{ GPM}}{0,816 \text{ (Temperature of } 6^{\circ} \text{ C)}} = 1,102 \text{ GPM}$$

Calculation of yield loss:

$$\frac{(\text{Initial PEP} - \text{PEP after rinsing})}{\text{Initial PEP}} \times 100 = \% \text{ loss}$$

$$\frac{(1,392 - 1,102)}{1,392} \times 100 = 20,83\% \text{ of yield loss or } 79,17\% \text{ efficiency}$$

Correction Factor Table

The drop in membrane performance is due to variations in sap quality. At the beginning and end of the sugaring season, sap will tend to clog membranes more quickly than in the middle of the season. A 15% drop in performance during the concentration operation must be followed by washing to avoid clogging.

Correction Factor Table	
Temperature in °C °F	Correction Factor
0/32	0,672
1/34	0,695
2/36	0,719
3/37	0,742
4/39	0,766
5/41	0,790
6/43	0,816
7/45	0,842
8/46	0,866
9/48	0,893
10/50	0,919
11/52	0,946
12/54	0,973
13/55	1
14/57	1,028
15/59	1,055
16/61	1,084
17/63	1,112
18/64	1,142
19/66	1,170
20/68	1,2
21/70	1,229
22/72	1,259
23/73	1,289
24/75	1,319
25/77	1,350

PEP Tests Results Table

Date	Pressure	Filtrate Flow Results	Temperature	Corrected Result at 13°C

WARRANTY

Hobby 350G limited warranty

This CDL product is offered with a two-year (two consecutive sugar seasons) limited workshop warranty against manufacturing defects. Breakage due to freezing, wear, abuse, poor maintenance or abnormal use is not covered.

The warranty covers only the product itself, and not any loss of yield, production or other damage it may cause. This warranty does not cover products installed contrary to the installation instructions in the manual or used under abnormal mechanical or environmental conditions. The warranty does not cover damage caused by failure to follow the recommendations in the user's manual.

The pre-filter and membranes are not covered by this warranty. Parts found to be defective are subject to inspection by CDL, who will confirm or deny that said product is subject to a manufacturing defect. If so, the product will be replaced or repaired at CDL's sole discretion. The warranty for electric motors is covered only upon approval by the CDL service department. Any electrical or electronic device or component whose power source is a generator is not covered by the CDL warranty. Problems caused by variations in electrical voltage are not covered.

Pre-filter and membranes are not covered by this warranty. Parts found to be defective are subject to inspection by CDL, who will confirm or deny that said product is subject to a manufacturing defect. If so, the product will be replaced or repaired at CDL's sole discretion.

Freight charges

All transportation costs related to the replacement or repair of products shipped to CDL's factory must be paid in advance by the Customer.

For technical assistance or support, please contact your CDL representative, your local CDL store or the CDL technical support team

Les Équipements d'Érablière CDL
257, route 279
Saint-Lazare-de-Bellechasse, (Québec) G0R
3J0 Canada

418-883-5158 | 1-800-361-5158
cdlinc.ca

CDL USA
3 Lemnah Drive
St. Albans VT 05478 United States

802-527-0000 | 1-800-762-5587
cdlusa.com

NOTES
