



Owner's Manual

Version 1.0 | 11/18/2024
668411-2.0-MAN-EN

VACUUM PROTECTION VALVE 2.0 CDL



Table of Contents

Introduction	3
Product Details	3
Component Identification.....	4
Technical Details.....	5
Operation	6
Installation.....	7
Drilling and tapping a hole in the extractor	8
Installation de la flotte dans l'extracteur	10
Timer Adjustment	11
Storage	12
Troubleshooting	12
Warranty	13
Notes.....	14

Introduction

Thank you for choosing the **vacuum protection valve** from CDL Sugaring Equipment. We are proud to offer high-quality products designed to meet the demanding needs of the maple sugaring industry. This user manual is designed to help you get the most out of your equipment by providing clear, detailed instructions for installation, use, maintenance, and troubleshooting as needed.

At CDL, we are committed to continuously innovating and improving our products to provide you with the most effective and reliable solutions. We encourage you to read this manual carefully and keep it for future reference. It is also available on our website. If you have any questions or concerns, please do not hesitate to contact our technical support team, who will be happy to assist you.

Thank you for trusting CDL for your maple sugaring equipment needs.

Product Details

The CDL **Vacuum Protection Valve 2.0** is a protective system for your vacuum pump, specifically designed to prevent sap from entering the pump's vacuum network in cases of abnormal sap flows or extractor malfunctions. When the sap level in the extractor becomes too high, an electric valve automatically closes the vacuum line, thereby preventing sap from reaching the pump.

By adding the optional **drain valve** (#73046VPV), this system can also automatically drain the CDL moisture trap when the vacuum line closes, in case sap has entered the trap.

Note: The drain valve will remain active until the indicator light returns to green.

Component Identification

#	Numéro / Part number	Qte / Qty	Description (Fr)	Description (Eng)	No. d'inventaire / Stock Code
1	CDLSTD-A00222	1	PERCAGE ADAPTEUR 664698	ADAPTER 664698 MACHINING	CDLSTD-A00222
2	CDLSTD-A00223	1	ASS. INTERRUPTEUR DE NIVEAU DE FLOTTE VERT.	VERT. LEVEL SENSOR ELECT. SS FLOAT SWITCH ASS'Y	CDLSTD-A00223
3	PVPV2.0	1	BOITIER ELECTRIQUE VALVE DE PROTECTION VACUUM 2.0	VACUUM PROTECTION VALVE 2.0 ELECTRICAL BOX	PVPV2.0
4	73049VPV	1	ASSEMBLAGE VALVE ELECTRIQUE PROTECTION VACUUM 2.0	ELECTRIC VALVE VACUUM PROTECTION ASSEMBLY 2.0	73049VPV
5	21043	1	TRANSFO ALIMENTATION 24V 3A 5.5MM X 2.5MM SANS FIL	POWER SUPPLY 24V 3A 5.5MM X 2.5MM W/O CORD	21043
6	520289	1	CABLE ALIMENTATION 110 VOLTS	110 VOLT POWER CABLE	520289

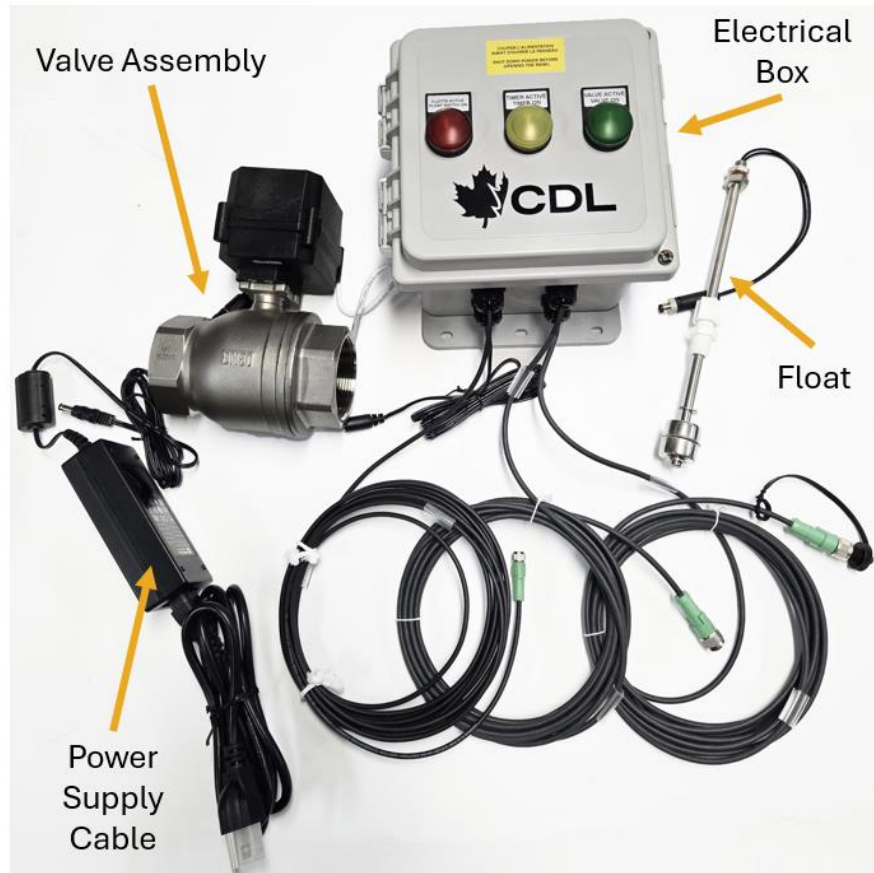

Technical Details

Electrical consumption: 120V, 1.7A.

Connection capacity: The device is equipped with two outputs, allowing control of two valves simultaneously for installations with two vacuum pumps. The basic set includes one valve, but an additional valve with connector (#73049VPV) can be added.

Important: A single float controls both valves, so it is not possible to use two separate floats for each valve. In case of excessive sap levels, the single float will close both valves simultaneously.

Material and fittings: The valve is made of stainless steel with a 2" female NPT fitting.

Indicator lights: The device is equipped with three indicator lights to show operational status.

Red Light: The float is activated, indicating that the sap level is high.

Yellow Light: A 2-minute delay is activated via the timer. During this delay, the valve remains closed and will automatically reopen after the time has expired.

Green Light: The valve is activated (open), allowing vacuum passage.

Additionally, the float height is adjustable to suit your needs.

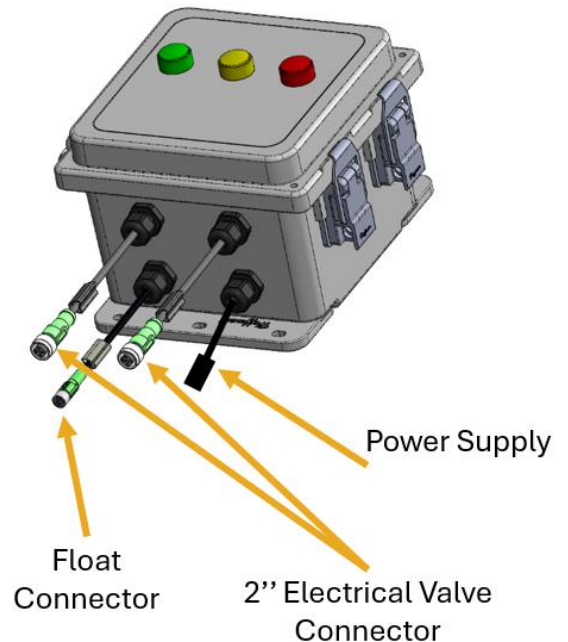
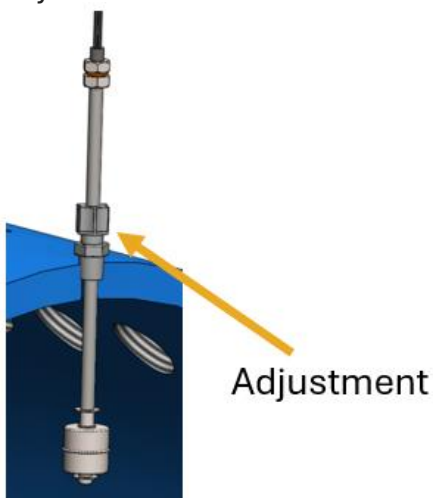

Operation

The **Vacuum Protection Valve 2.0** is designed to automatically close the vacuum line when the sap level in the extractor becomes too high. This action is controlled by a float installed inside the extractor, which opens or closes the valve based on the sap level.

- **Pump protection:** By closing the vacuum line, the valve prevents sap from reaching the pump, reducing the risk of damage.
- **Reopening delay:** Once the extractor pump has lowered the sap level below the float, a 2-minute delay is activated before the valve reopens. This delay allows the extractor to sufficiently clear sap, avoiding frequent opening and closing cycles that could compromise system performance. A shorter delay could also lead to frequent start-stops of the vacuum pump, which could damage the motor.
- **Operation during power outages:** In the event of a power outage, the valve closes automatically to protect the pump. This function is enabled by an internal capacitor that stores enough energy to close the valve in the event of power loss.

Note: The valve must be connected to the power source for at least 60 seconds to allow the capacitor to fully recharge. Once power is restored, the capacitor recharges, and the valve is ready to close again if the sap level rises or in the event of another power outage.

- **Optional drain valve:** By adding the optional drain valve (#73046VPV), the system can also automatically drain the CDL moisture trap when the vacuum line closes, in case sap has entered the trap. The drain valve will remain active (open) until the indicator light returns to green.

Installation

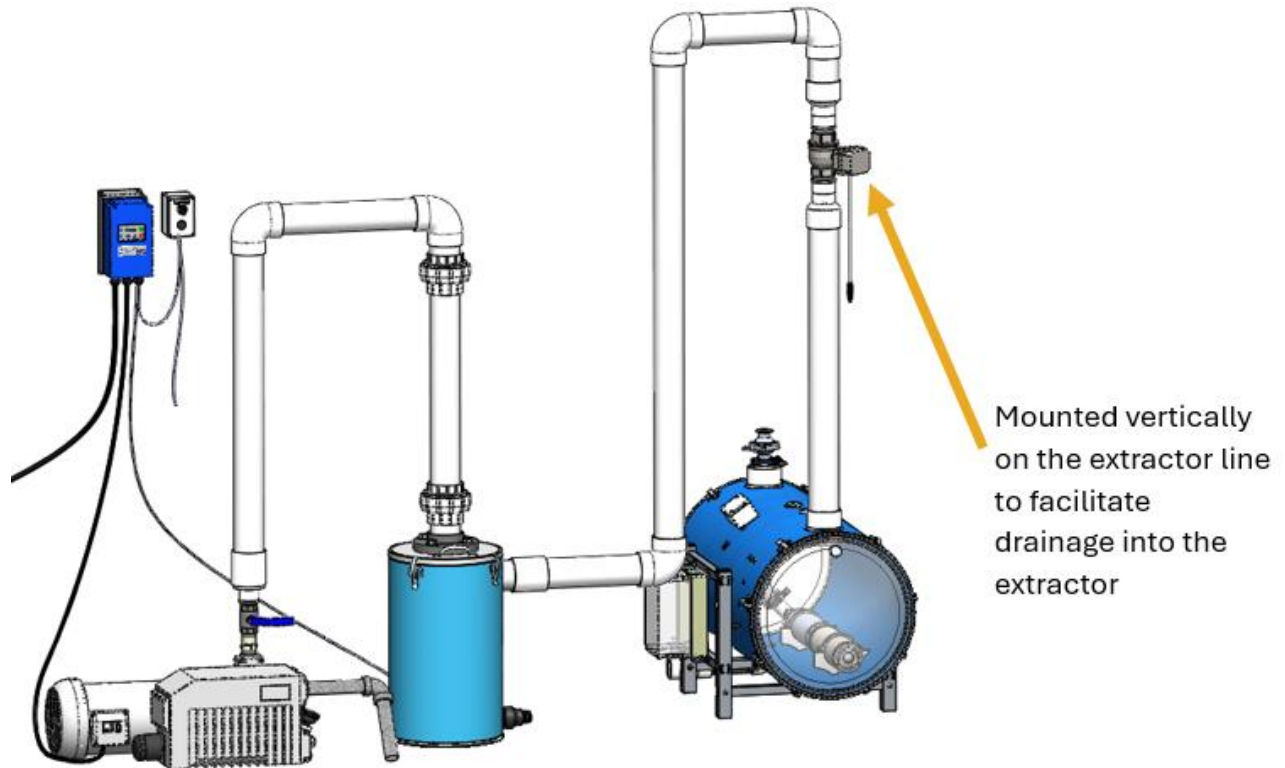

This diagram shows the typical installation of the protection valve on the vacuum line leading to the vacuum pump. While this configuration serves as a general guide, it may vary according to each customer's specific needs. Be sure to follow these guidelines for effective installation:

Valve Position: Install the valve as high as possible relative to the extractor. The higher the valve is placed, the more time it has to close before sap reaches the pump.

Vertical Orientation: Attach the valve to a vertical section of the extractor line. This setup allows the sap to flow back down into the extractor by gravity, reducing the risk of it becoming trapped in a horizontal section. In this way, sap will not be drawn toward the moisture trap or the pump when the valve reopens.

Drilling and tapping a hole in the extractor

If a new hole is needed in your extractor, your kit includes a drill bit and a tap to facilitate this operation. Follow the steps below for optimal installation.

1. **Marking the Location:** Identify the ideal spot for the hole using a marker. Ensure that this point is the highest on the extractor to maximize efficiency.



2. **Drilling :**

- Use the 7/16" drill bit provided in the kit along with a drill.
- Position the drill bit at the center of the marked spot and drill at a very low speed, keeping the bit as vertical as possible.



Tapping the hole :

- Use a tap wrench with the provided tap to begin threading. If you don't have a tap wrench, a ½" 12-point socket can be used.
- Turn the tap clockwise to start threading.
- After a few turns, rotate counterclockwise to break the chips, then continue turning clockwise.
- Continue threading until approximately three threads are visible on the tap.



3. **Cleaning:** Remove the tap and thoroughly clean the hole to remove any plastic debris, ensuring optimal sealing.



Installation de la flotte dans l'extracteur

1. **Removing the retaining rings:** To install the float rod, start by removing the two retaining rings. Use pliers and gently pull at the center of each ring to take it out of its groove.
2. **Inserting the rod:** Pass the rod through an existing ¼ NPT hole on top of the extractor or through a new threaded hole that you have drilled. Apply Teflon tape to the threads of the plastic adapter before screwing it in to ensure a proper seal.
3. **Orienting the float:** When reassembling, pay attention to the orientation of the float on the rod. If the float is reversed, it will alter the contact, which may affect its operation. Ensure that the side of the float with a mark is facing the bottom of the extractor.

1. Removing the retaining rings
(By their center)



2. Inserting the rod
(With Teflon tape)

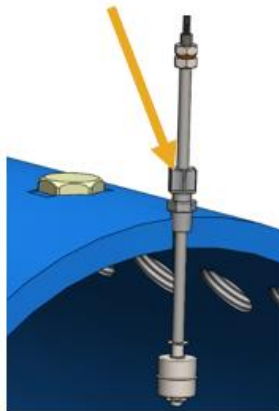

3. Float Orientation
(Point Facing Down)

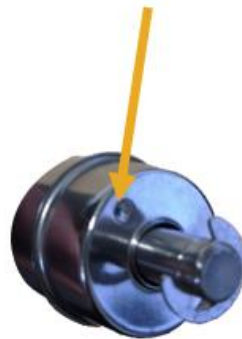

The float closes the valve when the sap level rises.

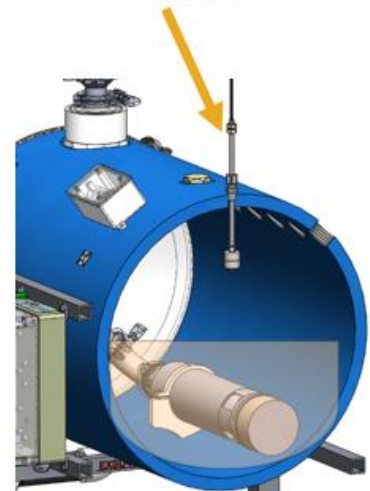

Timer Adjustment

The valve reopening delay can be adjusted to a different duration than the default 2 minutes. Follow these steps to adjust the delay:

1. **Disconnect the power:** Ensure the control panel's power supply is disconnected before proceeding.
2. **Access the timer relay:** Open the control panel and locate the timer relay (see the photo below for the exact location).
3. **Set the time scale:** Use a small flathead screwdriver to select the desired time scale by turning the arrow to the chosen option. Available options are: 1 second, 10 seconds, 100 seconds, 10 minutes, 1 hour, 10 hours, and 100 hours.
4. **Adjust the time percentage:** After selecting the time scale, adjust the delay by setting a percentage of this scale.

Adjustment example: If you select the 100-second scale and set the percentage to 60%, the reopening delay will be 60 seconds.



Percentage
%

Time Scale

**Function: Must stay
on function « A »**

Storage

Once the sugaring season is over, follow these steps to store the vacuum protection valve:

Cleaning the extractor and float: Thoroughly clean the inside of the extractor, paying close attention to the float. This will prevent debris buildup that could hinder the float's functionality.

Disconnecting the power: You may also disconnect the main power supply to the control box to power down the system.

Troubleshooting

This troubleshooting section is designed to help you quickly identify and resolve any issues you may encounter with your equipment. If problems persist, your representative or our customer service team is available to provide additional assistance.

Problems and Solutions

<p>The valve does not reopen after closing due to a water surge</p>	<ul style="list-style-type: none"> • Ensure no debris or dirt is obstructing the float's operation. • Make sure the timer delay has fully elapsed before the valve opens. • During installation, verify that the float is positioned the same way as it was upon delivery. If the float is reversed on the rod, it can invert the contact: a normally closed contact will become normally open, altering the valve's operation. • Ensure the electrical supply is functioning correctly. If there is a power issue, no lights will be on. Note that at least one indicator light should always be illuminated to show the system is working properly.
--	---

Warranty

The CDL vacuum protection valve is warranted for one year (one sugaring season) covering parts and labor in our workshop. This warranty includes manufacturing defects and breakdowns. The product must be used under normal conditions to be covered. Production losses are not covered. It is the user's responsibility to perform regular inspections to ensure the proper functioning of the vacuum protection valve.

Exclusions

This warranty does not cover the following:

1. Products whose original serial number has been removed, altered, or is illegible.
2. Equipment that has changed ownership or is located outside North America.
3. Failure to follow the maintenance procedure.
4. Production losses due to any issue with the CDL vacuum protection valve.
5. Revenue losses due to any issue with the CDL vacuum protection valve.
6. Service calls for issues unrelated to malfunction, manufacturing defects, or material defects, or for products not used in accordance with the provided instructions.
7. Service calls to verify installation or to obtain instructions on the equipment's use.
8. Service calls after one year.
9. Damage caused by repairs performed by unauthorized technicians; use of parts other than original CDL parts or parts not obtained through an authorized technician; and external causes such as abuse, misuse, accidents, fires, or natural disasters.
10. If the vacuum protection valve is damaged due to misuse, negligence, customer modifications, or electrical issues.
11. Damage caused by using products not intended for use with this equipment or improper use of cleaning or lubricating products.

CDL Sugaring Equipment

257, route 279, Saint-Lazare-de-Bellechasse (Québec) G0R 3J0 Canada

418 883-5158 | 1 800 361-5158

cdlinc.ca



